



Window Air Conditioner



User's Guide

Models:

IWA08-VSA26

IWA10-VSA26

IWA12-VSA26

www.impecca.com

CONTENTS

| | |
|---------------------------------------|----|
| IMPORTANT SAFETY INSTRUCTIONS | 1 |
| ASSEMBLING YOUR AIR CONDITIONER | 10 |
| USING YOUR AIR CONDITIONER | 19 |
| CLEANING AND MAINTENANCE | 24 |
| TROUBLESHOOTING | 25 |

* The design and specifications are subject to change without prior notice for product improvement. Consult with the sales agency or manufacturer for details.

* The shape and position of buttons and indicators may vary according to the model, but their function are the same.

IMPORTANT SAFETY INSTRUCTIONS

Read All Instructions and Cautionary Markings Before Operation and Installation to prevent death or injury to the user or other people and property damage, the following instructions must be followed. Incorrect operation due to ignoring of instructions may cause death, harm or damage.



This symbol indicates the possibility of personnel injury or loss of life.



This symbol indicates the possibility of property damage or serious consequences.

WARNING

1. Installation must be performed according to the installation instructions. Improper installation can cause water leakage, electrical shock, or fire.
2. Use only the included accessories and parts, and specified tools for the installation. Using nonstandard parts can cause water leakage, electrical shock, fire, and injury or property damage.
3. Make sure that the outlet you are using is grounded and has the appropriate voltage. The power cord is equipped with a three-prong grounding plug to protect against shock. Voltage information can be found on the nameplate of the appliance.
4. Your appliance must be used in a properly grounded wall receptacle. If the wall receptacle you intend to use is not adequately grounded or protected by a time delay fuse or circuit breaker (the fuse or circuit breaker needed is determined by the maximum current of the appliance. The maximum current is indicated on the nameplate located on the appliance), have a qualified electrician install the proper receptacle.
4. Install the appliance on a flat, sturdy surface. Failure to do so could result in damage or excessive noise and vibration.
6. The appliance must be kept free from obstruction to ensure proper function and to mitigate safety hazards.
7. Do not modify the length of the power cord or use an extension cord to power the appliance.
8. Do not share a single outlet with other electrical appliances. Improper power supply can cause fire or electrical shock.
9. Do not install your air conditioner in a wet room such as a bathroom or laundry room. Too much exposure to water can cause electrical components to short circuit.
10. Do not install the appliance in a location that may be exposed to combustible gas, as this could cause fire.
11. The appliance has wheels to facilitate moving. Make sure not to use the wheels on thick carpet or to roll over objects, as these could cause tipping.
12. Do not operate the appliance if it has been dropped or damaged.
13. The appliance with electric heater shall have at least 3 feet / 1 meter space away from the combustible materials.
14. Do not touch the appliance with wet or damp hands or when barefoot.
15. If the air conditioner is knocked over during use, turn off the appliance and unplug it from the main power supply immediately. Visually inspect the appliance to ensure there is no damage. If you suspect the appliance has been damaged, contact a technician or customer service for assistance.

IMPORTANT SAFETY INSTRUCTIONS

16. In a thunderstorm, the power must be cut off to avoid damage to the machine due to lightning. Your air conditioner should be used in such a way that it is protected from moisture. e.g. condensation, splashed water, etc. Do not place or store your air conditioner where it can fall or be pulled into water or any other liquid. Unplug immediately if it occurs.
17. All wiring must be performed strictly in accordance with the wiring diagram located inside of the appliance.
18. The appliance's circuit board (PCB) is designed with a fuse to provide overcurrent protection. The specifications of the fuse are printed on the circuit board, such as: T 3.15A / 250V, etc.
19. After proper installation, condensate will not overflow during normal use. If the fan hits the built-up water and the sound annoys you, please remove the cap located at the back of the air conditioner to drain the water away.

CAUTION

1. This appliance can be used by children aged from 8 years and above and person with reduced physical, sensory or mental capabilities or lack of experience and knowledge if they have been given supervision or instruction concerning use of the appliance in a safe way and understand the hazards involved. Children shall not play with the appliance. Cleaning and user maintenance shall not be made by children without supervision. (be applicable for the European Countries)
2. This appliance is not intended for use by persons (including children) with reduced physical, sensory or mental capabilities or lack of experience and knowledge, unless they have been given supervision or instruction concerning use of the appliance by a person responsible for their safety. Children should be supervised to ensure that they do not play with the appliance. Children must be supervised around the appliance at all times. (Be applicable for other countries except the European Countries.)
3. If the supply cord is damaged, it must be replaced by the manufacturer, its service agent or similarly qualified persons in order to avoid a hazard.
4. Prior to cleaning or other maintenance, the appliance must be disconnected from the supply mains.
5. Never use this appliance if it is not working properly, or if it has been dropped or damaged.
6. Do not run cord under carpeting. Do not cover cord with throw rugs, runners, or similar coverings. Do not route cord under furniture or appliances. Arrange cord away from traffic area and where it will not be tripped over.
7. Do not operate with a damaged cord, plug, power fuse or circuit breaker. Discard the appliance or return to an authorized service facility for examination and/or repair.
8. To reduce the risk of fire or electric shock, do not use this fan with any solid-state speed control device.
9. The appliance shall be installed in accordance with national wiring regulations.
10. Contact the authorized service technician for repair or maintenance of this appliance.
11. Contact the authorized installer for installation of this appliance.
12. Do not cover or obstruct the inlet or outlet grilles.

IMPORTANT SAFETY INSTRUCTIONS

13. Do not use this product for functions other than those described in this instruction manual.
14. Before cleaning, turn off the power and unplug the appliance.
15. Disconnect the power if strange sounds, smell, or smoke comes from it.
16. Do not press the buttons on the control panel with anything other than your fingers.
17. Do not operate or stop the appliance by inserting or pulling out the power cord plug.
18. Do not use hazardous chemicals to clean or come into contact with the appliance.
Do not use the appliance in the presence of inflammable substances or vapour such as alcohol, insecticides, petrol, etc.
19. Always contact a qualified person to carry out repairs. If the damaged power supply cord must be replaced with a new power supply cord obtained from the product manufacturer and not repaired.
20. Hold the plug by the head of the power plug when taking it out.
21. Turn off the product when not in use.

Operation of Current Device

The power supply cord contains a current measuring device that detects damage to the power cord. Test your power supply cord as follows:

1. Plug in the air conditioner.
2. The power supply cord will have TWO buttons on the plug head. Press the TEST button. You will notice a click as the RESET button pops out.
3. Press the RESET Button. You will notice a click as the button engages.
4. The power supply cord is now supplying electricity to the unit.
(On some products this is also indicated by a light on the plug head.)

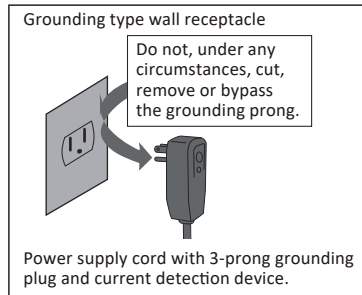
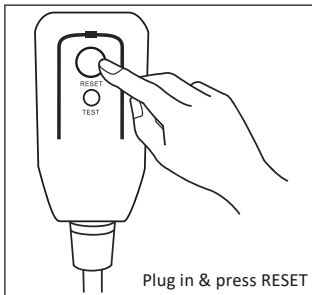

NOTE:

1. The power supply cord with this air conditioner contains a current detection device designed to reduce the risk of fire.
2. In the event that the power supply cord is damaged, it can not be repaired. It must be replaced with a cord from the manufacturer.
3. Do not use this device to turn the unit on or off.
4. Always make sure the RESET button is pushed in for correct operation.
5. The power supply cord must be replaced if it fails to reset when either the TEST button is pushed, or it can not be reset. Please contact Customer Service.

IMPORTANT SAFETY INSTRUCTIONS

WARNING FOR USING R32 REFRIGERANT

For R32 refrigerant models:

1. Appliance shall be installed, operated and stored in a room with a floor area larger than 4 m².
2. Appliance shall not be installed in an unventilated space, if that space is smaller than 4 m².
3. Compliance with national gas regulations shall be observed.
4. Keep ventilation openings clear of obstruction.
5. The appliance shall be stored so as to prevent mechanical damage from occurring.
6. A warning that the appliance shall be stored in a well-ventilated area where the room size corresponds to the room area as specified for operation.
7. Any person who is involved with working on or breaking into a refrigerant circuit should hold a current valid certificate from an industry-accredited assessment authority, which authorises their competence to handle refrigerants safely in accordance with an industry recognised assessment specification.
8. Servicing shall only be performed as recommended by the equipment manufacturer. Maintenance and repair requiring the assistance of other skilled personnel shall be carried out under the supervision of the person competent in the use of flammable refrigerants.
9. Please follow the instruction carefully to handle, install, clear, service the air conditioner to avoid any damage or hazard. Flammable Refrigerant R32 is used within air conditioner. When maintaining or disposing the air conditioner, the refrigerant (R32) shall be recovered properly, shall not discharge to air directly.
10. No any open fire or device like switch which may generate spark/arc shall be around air conditioner to avoid causing ignition of the flammable refrigerant used.
11. Please follow the instruction carefully to store or maintain the air conditioner to prevent mechanical damage from occurring.
12. Flammable refrigerant -R32 is used in air conditioner. Please follow the instruction carefully to avoid any hazard.
13. For specific information on the type of gas and the amount, please refer to the relevant label on the unit itself.



Caution: Risk of fire/flammable materials
(Required for R32 units only)







Warning: low burning velocity material
(For R32 models apply to IEC60335-2-40:2018)

Note about Fluorinated Gases

1. Fluorinated greenhouse gases are contained in hermetically sealed equipment. For specific information on the type, the amount and the Co₂ equivalent in tonnes of the fluorinated greenhouse gas (on some models), please refer to the relevant label on the unit itself.
2. Installation, service, maintenance and repair of this unit must be performed by a certified technician.
3. Product uninstallation and recycling must be performed by a certified technician.

IMPORTANT SAFETY INSTRUCTIONS

Explanation of symbols displayed on the unit:

| | | |
|--|---------|---|
|  | WARNING | This symbol shows that this appliance used a flammable refrigerant. If the refrigerant is leaked and exposed to an external ignition source, there is a risk of fire. |
|  | CAUTION | This symbol shows that the operation manual should be read carefully. |
|  | CAUTION | This symbol shows that a service personnel should be handling this equipment with reference to the installation manual. |
|  | CAUTION | This symbol shows that information is available such as the operating manual or installation manual. |

FOR HOUSEHOLD USE ONLY READ AND SAVE THESE INSTRUCTIONS

1. Transport of equipment containing flammable refrigerants

See transport regulations.

2. Marking of equipment using signs

See local regulations.

3. Disposal of equipment using flammable refrigerants

See national regulations.

4. Storage of equipment/appliances

The storage of equipment should be in accordance with the manufacturer's instructions.

5. Storage of packed (unsold) equipment

Storage package protection should be constructed such that mechanical damage to the equipment inside the package will not cause a leak of the refrigerant charge. The maximum number of pieces of equipment permitted to be stored together will be determined by local regulations.

6. Information on servicing

1) Checks to the area

Prior to beginning work on systems containing flammable refrigerants, safety checks are necessary to ensure that the risk of ignition is minimised. For repair to the refrigerating system, the following precautions shall be complied with prior to conducting work on the system.

2) Work procedure

Work shall be undertaken under a controlled procedure so as to minimise the risk of a flammable gas or vapour being present while the work is being performed.

3) General work area

All maintenance staff and others working in the local area shall be instructed on the nature of work being carried out. Work in confined spaces shall be avoided. The area around the workspace shall be sectioned off. Ensure that the conditions within the area have been made safe by control of flammable material.

4) Checking for presence of refrigerant

The area shall be checked with an appropriate refrigerant detector prior to and during work, to ensure the technician is aware of potentially flammable atmospheres. Ensure that the leak detection equipment being used is suitable for use with flammable refrigerants, i.e. non-sparking, adequately sealed or intrinsically safe.

IMPORTANT SAFETY INSTRUCTIONS

5) Presence of fire extinguisher

If any hot work is to be conducted on the refrigeration equipment or any associated parts, appropriate fire extinguishing equipment shall be available to hand. Have a dry powder or CO2 fire extinguisher adjacent to the charging area.

6) No ignition sources

No person carrying out work in relation to a refrigeration system which involves exposing any pipe work that contains or has contained flammable refrigerant shall use any sources of ignition in such a manner that it may lead to the risk of fire or explosion. All possible ignition sources, including cigarette smoking, should be kept sufficiently far away from the site of installation, repairing, removing and disposal, during which flammable refrigerant can possibly be released to the surrounding space. Prior to work taking place, the area around the equipment is to be surveyed to make sure that there are no flammable hazards or ignition risks. No Smoking signs shall be displayed.

7) Ventilated area

Ensure that the area is in the open or that it is adequately ventilated before breaking into the system or conducting any hot work. A degree of ventilation shall continue during the period that the work is carried out. The ventilation should safely disperse any released refrigerant and preferably expel it externally into the atmosphere.

8) Checks to the refrigeration equipment

Where electrical components are being changed, they shall be fit for the purpose and to the correct specification. At all times the manufacturer's maintenance and service guidelines shall be followed. If in doubt consult the manufacturer's technical department for assistance. The following checks shall be applied to installations using flammable refrigerants:

- a. The charge size is in accordance with the room size within which the refrigerant containing parts are installed;
- b. The ventilation machinery and outlets are operating adequately and are not obstructed;
- c. If an indirect refrigerating circuit is being used, the secondary circuit shall be checked for the presence of refrigerant; Marking to the equipment continues to be visible and legible. Markings and signs that are illegible shall be corrected;
- d. Refrigeration pipe or components are installed in a position where they are unlikely to be exposed to any substance which may corrode refrigerant containing components, unless the components are constructed of materials which are inherently resistant to being corroded or are suitably protected against being so corroded.

9) Checks to electrical devices

Repair and maintenance to electrical components shall include initial safety checks and component inspection procedures. If a fault exists that could compromise safety, then no electrical supply shall be connected to the circuit until it is satisfactorily dealt with. If the fault cannot be corrected immediately but it is necessary to continue operation, an adequate temporary solution shall be used. This shall be reported to the owner of the equipment so all parties are advised. Initial safety checks shall include:

- a. That capacitors are discharged: this shall be done in a safe manner to avoid possibility of sparking;
- b. That there are no live electrical components and wiring are exposed while charging, recovering or purging the system;
- c. That there is continuity of earth bonding.

IMPORTANT SAFETY INSTRUCTIONS

7. Repair to intrinsically safe components

Do not apply any permanent inductive or capacitance loads to the circuit without ensuring that this will not exceed the permissible voltage and current permitted for the equipment in use. Intrinsically safe components are the only types that can be worked on while live in the presence of a flammable atmosphere. The test apparatus shall be at the correct rating. Replace components only with parts specified by the manufacturer. Other parts may result in the ignition of refrigerant in the atmosphere from a leak.

8. Cabling

Check that cabling will not be subject to wear, corrosion, excessive pressure, vibration, sharp edges or any other adverse environmental effects. The check shall also take into account the effects of aging or continual vibration from sources such as compressors or fans.

9. Detection of flammable refrigerants

Under no circumstances shall potential sources of ignition be used in the searching for or detection of refrigerant leaks. A halide torch (or any other detector using a naked flame) shall not be used.

10. Leak detection methods

The following leak detection methods are deemed acceptable for systems containing flammable refrigerants. Electronic leak detectors shall be used to detect flammable refrigerants, but the sensitivity may not be adequate, or may need re-calibration. (Detection equipment shall be calibrated in a refrigerant-free area.) Ensure that the detector is not a potential source of ignition and is suitable for the refrigerant used. Leak detection equipment shall be set at a percentage of the LFL of the refrigerant and shall be calibrated to the refrigerant employed and the appropriate percentage of gas (25 % maximum) is confirmed. Leak detection fluids are suitable for use with most refrigerants but the use of detergents containing chlorine shall be avoided as the chlorine may react with the refrigerant and corrode the copper pipe-work. If a leak is suspected, all naked flames shall be removed/extinguished. If a leakage of refrigerant is found which requires brazing, all of the refrigerant shall be recovered from the system, or isolated (by means of shut off valves) in a part of the system remote from the leak. Oxygen free nitrogen (OFN) shall then be purged through the system both before and during the brazing process.

11. Removal and evacuation

When breaking into the refrigerant circuit to make repairs or for any other purpose conventional procedures shall be used. However, it is important that best practice is followed since flammability is a consideration. The following procedure shall be adhered to: Remove refrigerant; Purge the circuit with inert gas; Evacuate; Purge again with inert gas; Open the circuit by cutting or brazing. The refrigerant charge shall be recovered into the correct recovery cylinders. The system shall be flushed with OFN to render the unit safe. This process may need to be repeated several times. Compressed air or oxygen shall not be used for this task. Flushing shall be achieved by breaking the vacuum in the system with OFN and continuing to fill until the working pressure is achieved, then venting to atmosphere, and finally pulling down to a vacuum. This process shall be repeated until no refrigerant is within the system. When the final OFN charge is used, the system shall be vented down to atmospheric pressure to enable work to take place. This operation is absolutely vital if brazing operations on the pipe-work are to take place. Ensure that the outlet for the vacuum pump is not close to any ignition sources and there is ventilation available.

IMPORTANT SAFETY INSTRUCTIONS

12. Charging procedures

In addition to conventional charging procedures, the following requirements shall be followed. Ensure that contamination of different refrigerants does not occur when using charging equipment. Hoses or lines shall be as short as possible to minimise the amount of refrigerant contained in them. Cylinders shall be kept upright. Ensure that the refrigeration system is earthed prior to charging the system with refrigerant. Label the system when charging is complete (if not already). Extreme care shall be taken not to overfill the refrigeration system. Prior to recharging the system it shall be pressure tested with OFN. The system shall be leak tested on completion of charging but prior to commissioning. A follow up leak test shall be carried out prior to leaving the site.

13. Decommissioning

Before carrying out this procedure, it is essential that the technician is completely familiar with the equipment and all its detail. It is recommended good practice that all refrigerants are recovered safely. Prior to the task being carried out, an oil and refrigerant sample shall be taken in case analysis is required prior to re-use of reclaimed refrigerant. It is essential that electrical power is available before the task is commenced.

- a. Become familiar with the equipment and its operation.
- b. Isolate system electrically.
- c. Before attempting the procedure ensure that: Mechanical handling equipment is available, if required, for handling refrigerant cylinders; All personal protective equipment is available and being used correctly; The recovery process is supervised at all times by a competent person; Recovery equipment and cylinders conform to the appropriate standards.
- d. Pump down refrigerant system, if possible.
- e. If a vacuum is not possible, make a manifold so that refrigerant can be removed from various parts of the system.
- f. Make sure that cylinder is situated on the scales before recovery takes place.
- g. Start the recovery machine and operate in accordance with manufacturer's instructions.
- h. Do not overfill cylinders. (No more than 80 % volume liquid charge).
- i. Do not exceed the maximum working pressure of the cylinder, even temporarily.
- j. When the cylinders have been filled correctly and the process completed, make sure that the cylinders and the equipment are removed from site promptly and all isolation valves on the equipment are closed off.
- k. Recovered refrigerant shall not be charged into another refrigeration system unless it has been cleaned and checked.

14. Labelling

Equipment shall be labelled stating that it has been de-commissioned and emptied of refrigerant. The label shall be dated and signed. Ensure that there are labels on the equipment stating the equipment contains flammable refrigerant.

15. Recovery

When removing refrigerant from a system, either for servicing or decommissioning, it is recommended good practice that all refrigerants are removed safely. When transferring refrigerant into cylinders, ensure that only appropriate refrigerant recovery cylinders are employed. Ensure that the correct number of cylinders for holding the total system charge is available. All cylinders to be used are designated for the recovered refrigerant and labelled for that refrigerant (i.e. special cylinders for the recovery of refrigerant).

IMPORTANT SAFETY INSTRUCTIONS

Cylinders shall be complete with pressure relief valve and associated shut-off valves in good working order. Empty recovery cylinders are evacuated and, if possible, cooled before recovery occurs. The recovery equipment shall be in good working order with a set of instructions concerning the equipment that is at hand and shall be suitable for the recovery of flammable refrigerants. In addition, a set of calibrated weighing scales shall be available and in good working order. Hoses shall be complete with leak-free disconnect couplings and in good condition. Before using the recovery machine, check that it is in satisfactory working order, has been properly maintained and that any associated electrical components are sealed to prevent ignition in the event of a refrigerant release. Consult manufacturer if in doubt. The recovered refrigerant shall be returned to the refrigerant supplier in the correct recovery cylinder, and the relevant Waste Transfer Note arranged. Do not mix refrigerants in recovery units and especially not in cylinders. If compressors or compressor oils are to be removed, ensure that they have been evacuated to an acceptable level to make certain that flammable refrigerant does not remain within the lubricant. The evacuation process shall be carried out prior to returning the compressor to the suppliers. Only electric heating to the compressor body shall be employed to accelerate this process. When oil is drained from a system, it shall be carried out safely.









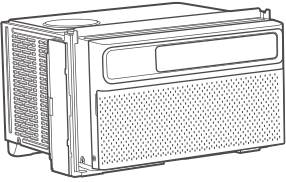

Gentle Reminder

Check the appliance regularly and refer to TROUBLESHOOTING or contact our customer support if it shows any of the following signs:

- Power cord or plug is damaged.
- Loud noise, unusual smell or excessive heat.

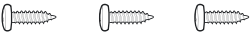
ASSEMBLING YOUR AIR CONDITIONER

Package Contents

| | Part Name | Quantity |
|---|-----------------------------------|----------|
|  | Window Air Conditioner | 1 |
|  | Remote Control | 1 |
|  | Long Foam Seal (Non-Adhesive) | 1 |
|  | Long Foam Seal (Adhesive) | 1 |
|  | Security Bracket | 1 |
|  | 3/4" Screw | 4 |
|  | 1/2" Screw | 3 |
|  | Remote Control Battery | 2 |
|  | Plasticene | 1 |
|  | Short Lock Frame (back-up use) | 2 |
|  | Long Lock Frame (back-up use) | 2 |

ASSEMBLING YOUR AIR CONDITIONER

Window Requirements

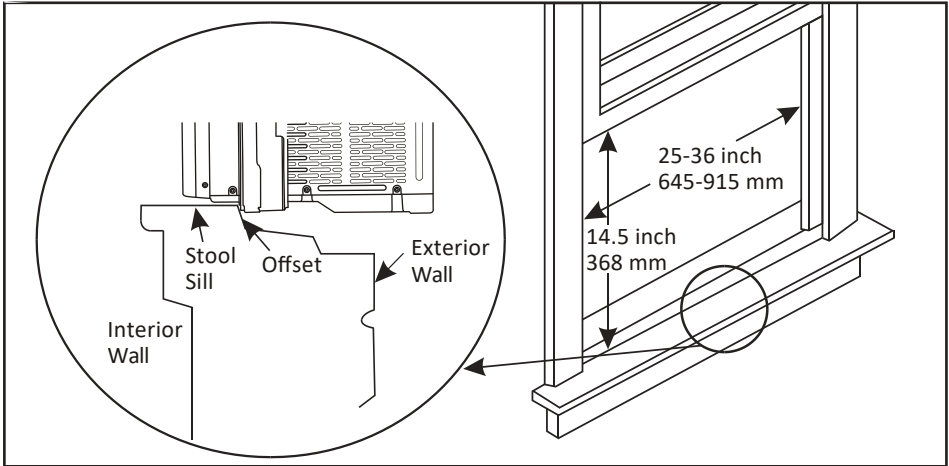

1. This air conditioner is designed to be installed in a standard single-hung or double-hung window with a window width between 25" and 36"(645mm- 915mm).
2. The air conditioner can be installed without the side panels to fit in a narrow window opening. See the window dimensions. If the air conditioner is installed on a window with a width of 645-720mm, the air conditioner must be installed to the right and the right bracket must be abut on the air conditioner, otherwise the air conditioner will not operate normally.
3. The lower sash (the lower part of the window that moves up and down) must allow for 14.5" of vertical clearance when open.
4. All supporting parts must be secured to firm wood, masonry or metal.
5. The electrical outlet must be within reach of the power cord.

NOTE:

1. Save the product packaging and installation instructions for future reference.
2. Store the air conditioner in the product box during winter or when not in use.

ASSEMBLING YOUR AIR CONDITIONER

Getting Started

SUGGESTED TOOLS FOR INSTALLATION (Not included)

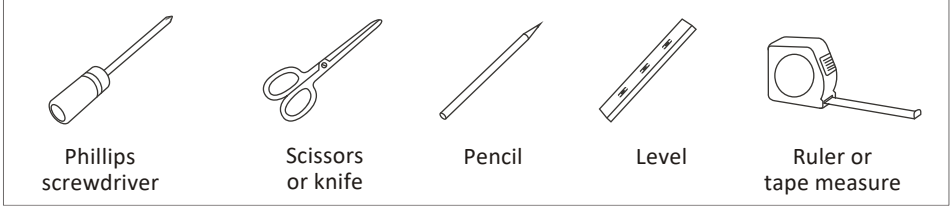

CAUTION:

Heavy object. Team handling is required during the installation process.

1. Removing All the Packaging

Carefully remove all the packaging straps and wraps from the air conditioner and accessories.

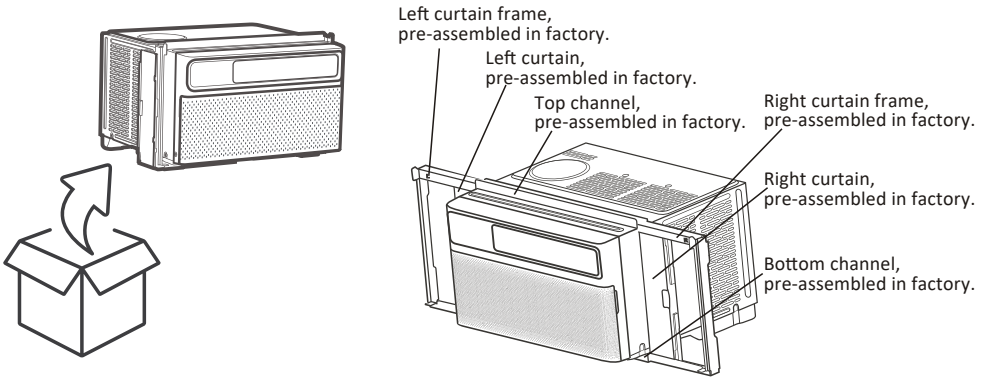

CAUTION:

When handling the unit, be careful to avoid cuts from the sharp metal edges and aluminum fins on the front and rear coils.

NOTE:

To be easy installation, both the left and right curtains, curtain frames, top channel, and bottom channel, are pre-assembled in factory.

2. Applying the Adhesive Foam Seal

Measure the length of the upper window frame, trim the adhesive foam seal to the appropriate length and apply as shown.

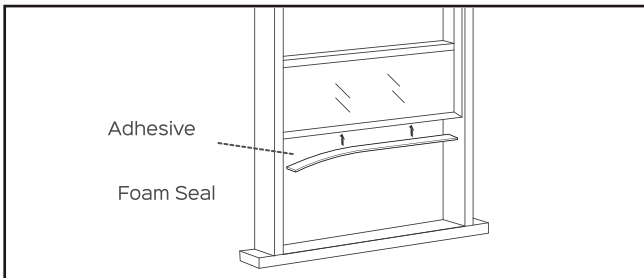

ASSEMBLING YOUR AIR CONDITIONER

3.Placing Inside an Open Window

Carefully lift the air conditioner with a helper to the windowsill and pull down the sash, making sure the air conditioner is centered and its bottom rail is flush against the windowsill.

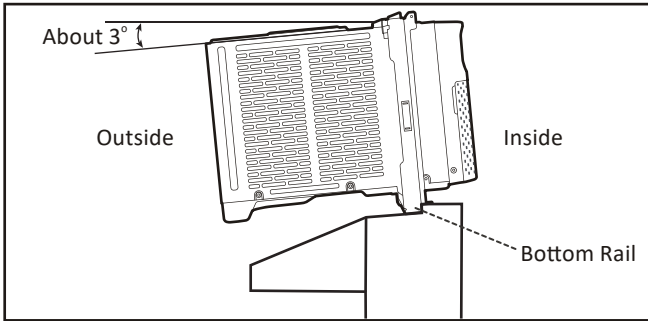

NOTE:

The air conditioner should be tilted about 3° for better drainage of condensate and rainwater. Use a level: about 1/3 bubble will show correct slant.

4.Securing the Side Brackets

Extend the side brackets from both sides of the air conditioner onto the left and right window frames and secure by installing four 3/4" screws as shown.

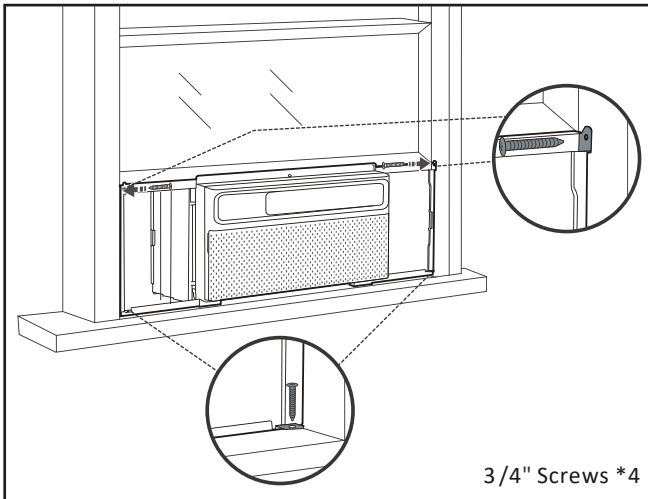

NOTE:

Fix the upper screws first, then the lower screws.

ASSEMBLING YOUR AIR CONDITIONER

5. Securing the Side Panels

Pull the side panels inwards to align with the brackets, then secure onto the sides by snapping the jutting points onto the locking pins.

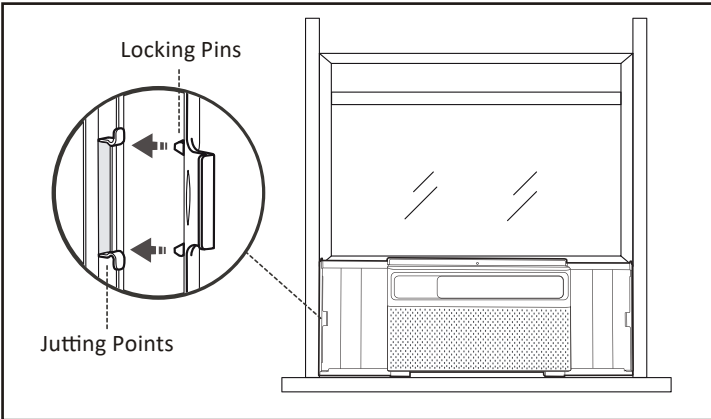

6. Sealing the Crevices with Plasticene (Optional)

Fill the crevices between the side brackets and panels with the included plasticene.

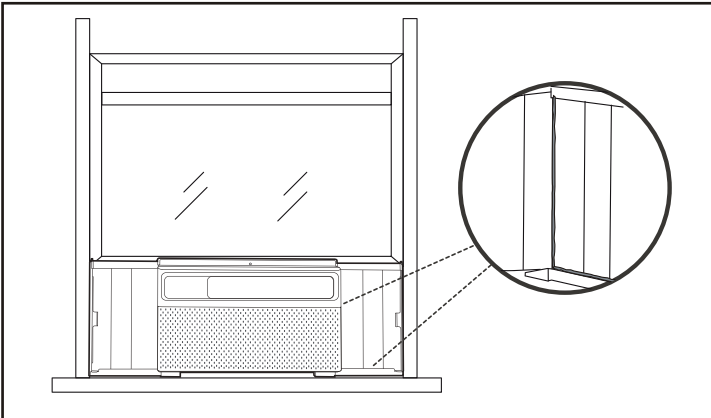

ASSEMBLING YOUR AIR CONDITIONER

7. Installing the Screw Into the Top Rail

Install the 1/2" screw into the top rail of the air conditioner.

Note: It is recommended to install this screw and remove it only when you need to open the window

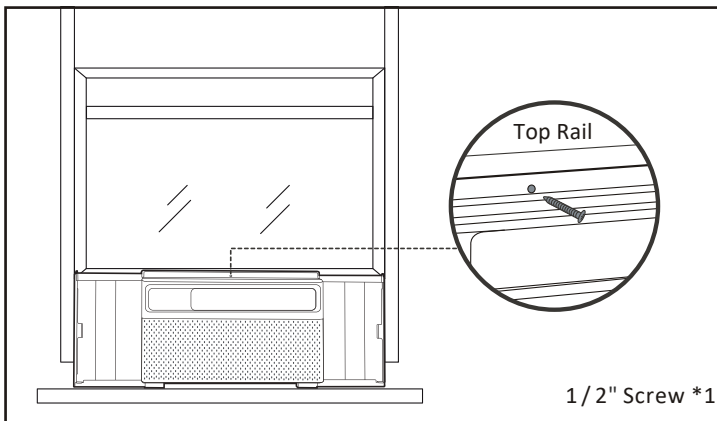

8. Applying the Panel Seals (optional)

Measure the length extended by the side panels, trim the panel seals to the appropriate length, peel off the backings and apply on the panels on both sides.

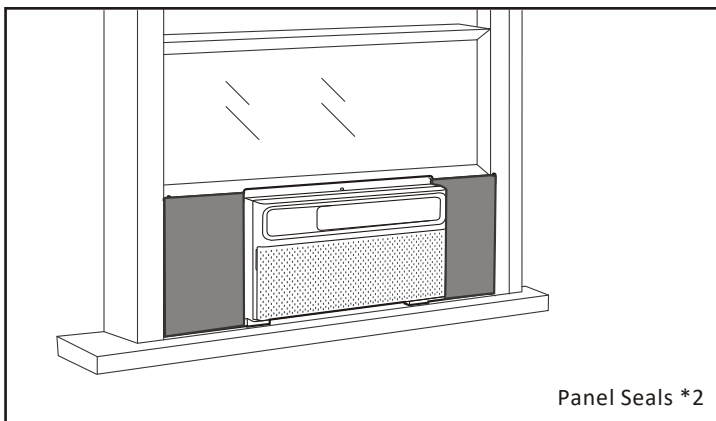

ASSEMBLING YOUR AIR CONDITIONER

9. Installing the Security Bracket

Attach the security bracket on top of the window sash and secure with two 1/2" screws.

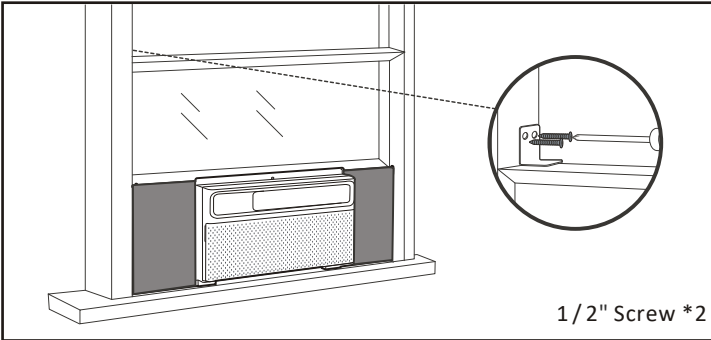

10. Filling the Gap Between Sashes

Trim the non-adhesive foam seal to the appropriate length and insert between the window sashes.

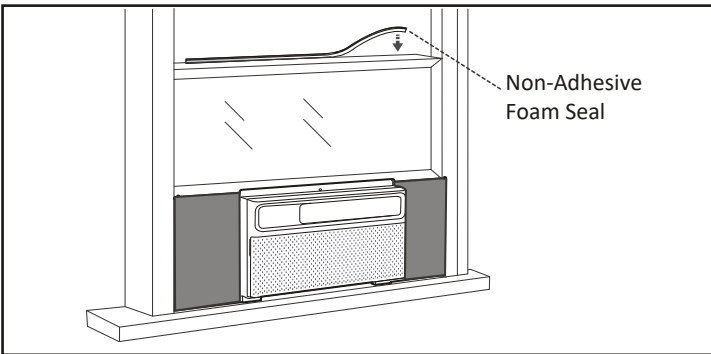

CAUTION:

When open the window, be sure that the fixed screws are available from the curtain to the window frame.

If AC Is Blocked By Storm Window

1. Add wood as shown, or remove storm window before air conditioner is installed.
2. If Storm Window Frame must remain, be sure the drain holes or slots are not caulked or painted shut. Accumulated Rain Water or Condensate must be allowed to drain out.

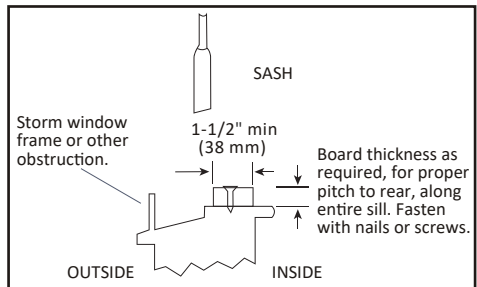

ASSEMBLING YOUR AIR CONDITIONER

For some special window frame, as too thin or too thick, you may need to use the back-up lock frame to do the additional fixed.

If the AC unit can not be screw-fixed well by the steel frame holes, you must use the back-up lock frame to do the additional fixed, as the aluminum alloy window.

1. Install the screw into the top channel of the AC unit, and screw into the window frame.
2. Select two suitable back-up using lock frames, fix them at the bottom of steel frame near the sides with screws.
3. If needed, you can use the other two back-up using lock frames to do the additional fix at the top area.

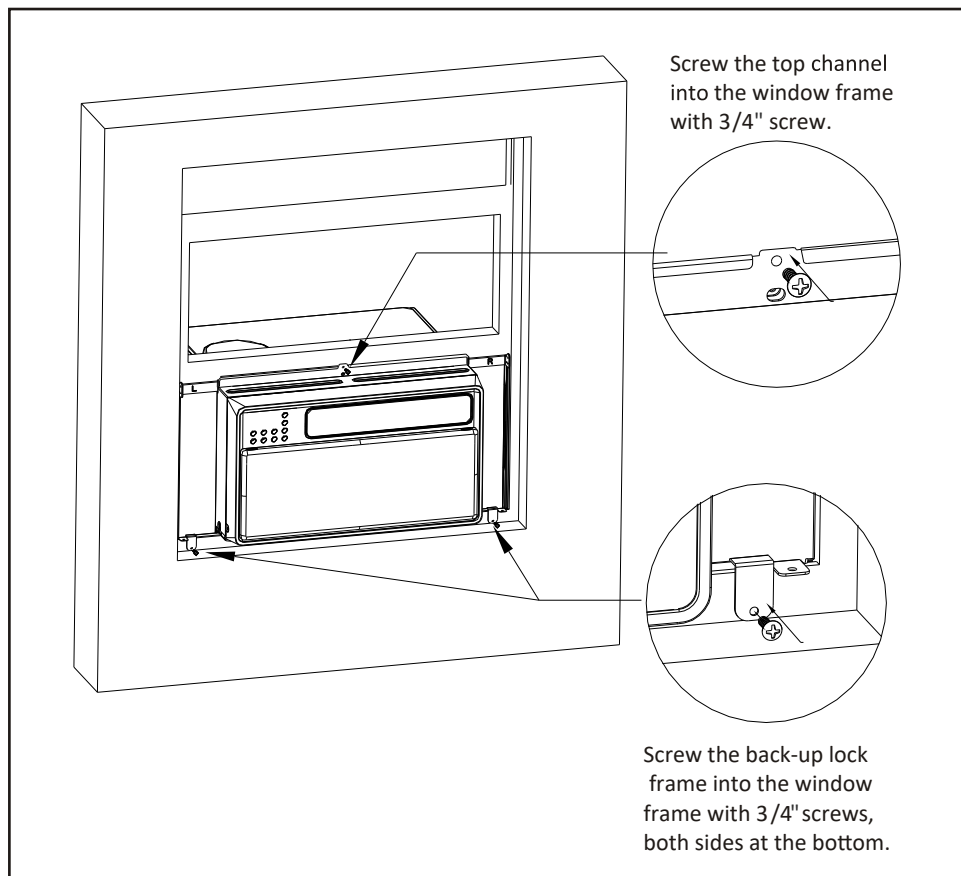

ASSEMBLING YOUR AIR CONDITIONER

Installation & Assembly Instructions

Important Considerations

1. Before installing the appliance, you must read the manual carefully to get the safety information and notes.
2. Unit refrigerant charge amount: refer to unit name plate marking.
3. A leak test must be done after the installation is completed.
4. It is a must to do the safety inspection before maintaining or repairing an air conditioner using combustible refrigerant in order to ensure that the fire risk is reduced to minimum.
5. It is necessary to operate the machine under a controlled procedure in order to ensure that any risk arising from the combustible gas or vapor during the operation is reduced to minimum.



Introduction to Refrigerants R32

1. Site Safety



Open Flames
Prohibited



Ventilation
Necessary

2. Operation Safety



Mind Static
Electricity



Must Wear
Protective Clothing
and Anti-Static
Gloves



Don't Use
Mobile Phone

3. Installation Safety



- Refrigerant Leak Detector
- Appropriate Installation Location
- The left picture is the schematic diagram of a refrigerant leak detector.

Please note that:

1. The installation site should be in a well-ventilated condition.
2. The sites for installing and maintaining an air conditioner using Refrigerant R32 should be free from open fire or welding, smoking, drying oven or any other heat source higher than 548 °C which easily produces open fire.
3. When installing an air conditioner, it is necessary to take appropriate anti-static measures such as wear anti-static clothing and/or gloves.
4. It is necessary to choose the site convenient for installation or maintenance wherein the air inlets and outlets of the indoor and outdoor units should be not surrounded by obstacles or close to any heat source or combustible and/or explosive environment.
5. If the indoor unit suffers refrigerant leak during the installation, all the personnel should go out till the refrigerant leaks completely for 15 minutes. If the product is damaged, it is a must to carry such damaged product back to the maintenance station and it is prohibited to weld the refrigerant pipe or conduct other operations on the user's site.
6. It is necessary to choose the place where the inlet and outlet air of the indoor unit is even.
7. It is necessary to avoid the places where there are other electrical products, power switch plugs and sockets, kitchen cabinet, bed, sofa and other valuables right under the lines on two sides of the indoor unit, and also prevent mechanical damage from occurring.



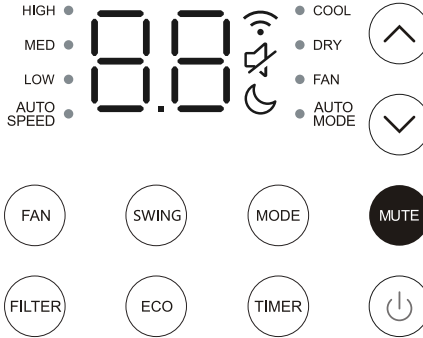



USING YOUR AIR CONDITIONER



| | |
|-------------------------|--|
| | Turn on the air conditioner or switch to standby. |
| | Adjust fan speed (Low, Med, High, Auto) NOTE: Fan speed setting is available in Auto, Cool, and Fan modes only. |
| | Select to adjust the airflow direction by swinging the louver vertically. |
| | Decrease the air conditioning temperature. |
| | Increase the air conditioning temperature. |
| | Switch between Cool/Dry/Fan/Auto mode. |
| | Remind to clean the dust filter. |
| | Turn on/off the ECO mode, under Cool/Dry mode. |
| | Timer on or Timer off the unit. |
| | Turn on/off the MUTE mode. |
| COOL DRY FAN AUTO MODE | Indicates Cool, Dry, Fan, and Auto mode, respectively. |
| | Indicates the unit is in Sleep mode. |
| | Indicates the unit is in MUTE mode. |
| | Indicates that there is a WiFi connection |
| HIGH MED LOW AUTO SPEED | Indicates Low, Medium, High, and Automatic fan speeds, respectively. |

USING YOUR AIR CONDITIONER

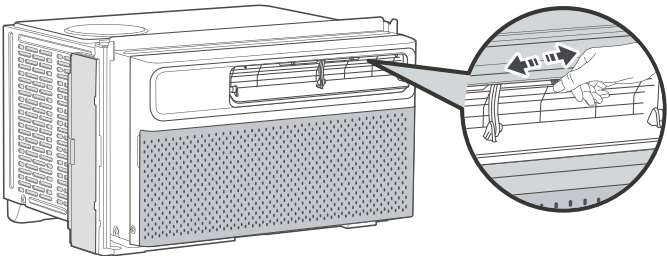





General Operations

| | |
|--|---|
|  <p>Power Button</p> | <p>Press to turn on the air conditioner or switch it to standby mode.</p> |
|  <p>Increase Button</p> | <p>Press to increase the air conditioning temperature by 1°F/°C.</p> |
|  <p>Decrease Button</p> | <p>Press to decrease the air conditioning temperature by 1°F/°C.</p> |
|  <p>Swing/ Oscillation Button</p> | <p>1.Press to make the louver move up and down. 2.Press again to stop the louver at the desired angle. NOTE: To adjust the airflow direction horizontally, manually move the levers located on top of the air outlet from side to side.</p> <p>NOTE: Do not adjust the big vertical louver by hand, otherwise will cause damage.</p>  |
|  <p>Fan Speed Button</p> | <p>Adjust Fan Speed Press repeatedly to adjust fan speed: Low, Med, High, and Auto.</p> |
|  <p>Filter Button</p> | <p>Reset Filter Reminder To clean the filter, see page below.</p> |



NOTE:

- In Auto speed, fan speed will adapt to the room temperature.
- In Dry Mode, fan speed cannot be adjusted.

USING YOUR AIR CONDITIONER

| | |
|--|---|
|  Mode Button  | <p>Press repeatedly to cycle through Cool, Dry, Fan and Auto modes.</p> <p>Cool Mode</p> <ul style="list-style-type: none"> - In Cool mode, the air conditioner cools the room to the desired temperature. - Temperature and fan speed are adjustable. <p>Dry Mode</p> <ul style="list-style-type: none"> - In Dry mode, the air conditioner works as a dehumidifier to remove humidity in the room. The fan is constantly running at a low speed. - Temperature and fan speed cannot be adjusted. <p>Fan Mode</p> <ul style="list-style-type: none"> - In Fan mode, the air conditioner circulates air like a normal fan. Remember to open the vent during this function, but keep it closed during cooling for maximum cooling efficiency. - Fan speed can be set to Low, Med, or High. - Temperature cannot be adjusted. <p>Auto Mode</p> <ul style="list-style-type: none"> - In Auto mode, the air conditioner adjusts its working mode (Cool or Fan) automatically based on the room temperature. - Temperature and fan speed cannot be adjusted. |
|  Timer Button  | <ul style="list-style-type: none"> - When the air conditioner is on standby/running, press the Timer button and its icon will flash on the remote display. During the flashing process, press + or - to select a timer from 0.5 to 24 hours, then press the Timer button again to confirm the setting. After the timer ends, the air conditioner will start/stop running automatically. - Turning the air conditioner ON or OFF at any time or adjusting the timer setting to 0.0 hour will cancel the timer program. |
|  Eco Mode Button | <p>In Eco mode, when the desired temperature is reached, the compressor will turn off and the fan will continue to run for 3 minutes. Then the fan cycles on for 1 minute at 5 minute intervals until the room temperature is above the set temperature, at which time the compressor turns back on and cooling restarts.</p> |
|  Mute Mode Button | <p>Turn on/off Mute mode</p> |

USING YOUR AIR CONDITIONER

| | |
|--|---|
|  <p>Sleep Mode Button (On Remote Control)</p> | <p>In Sleep mode, the air conditioning temperature will adjust gradually every 30 minutes to keep you comfortable while preventing overcooling. After 10 hours, Sleep mode will exit automatically and the temperature will return to the initial temperature.</p> <p>NOTE: In Sleep mode, all the button sounds will be muted, and all the indicators on the display will turn off after 15 seconds, except for the Sleep mode indicator.</p> |
|  <p>LED or Display Button (On Remote Control)</p> | <p>Turn on or off the display on the air conditioner.</p> |

Other Features

Filter Reminder

When the running time of the fan reaches 500 hours, the filter reminder will light up to remind you to clean the filter. To clean the filter, see page below.

Display Auto Off

- Display will dim after 30 seconds (off after 15 seconds in sleep mode).
- Wake up the display with any button.

Memory

If the air conditioner is turned OFF and stays connected to the power, it will operate under the previous settings (except the timer setting) when it is turned ON again.

Drain Water

After proper installation, condensate will not overflow during normal use.

If the fan hits the built-up water and the sound annoys you, please remove the cap located at the back of the air conditioner to drain the water away.

NOTE: Removing the cap may affect the heat transfer efficiency.

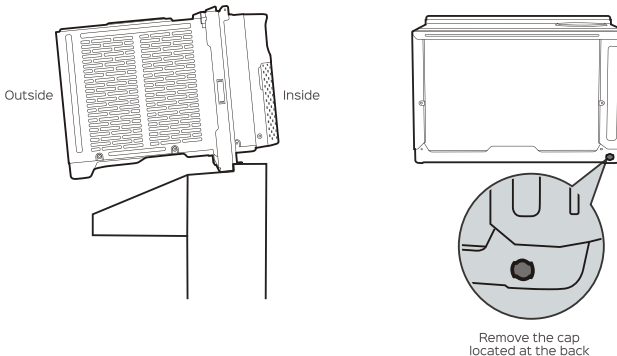

How to Control Your AC

Remote Control

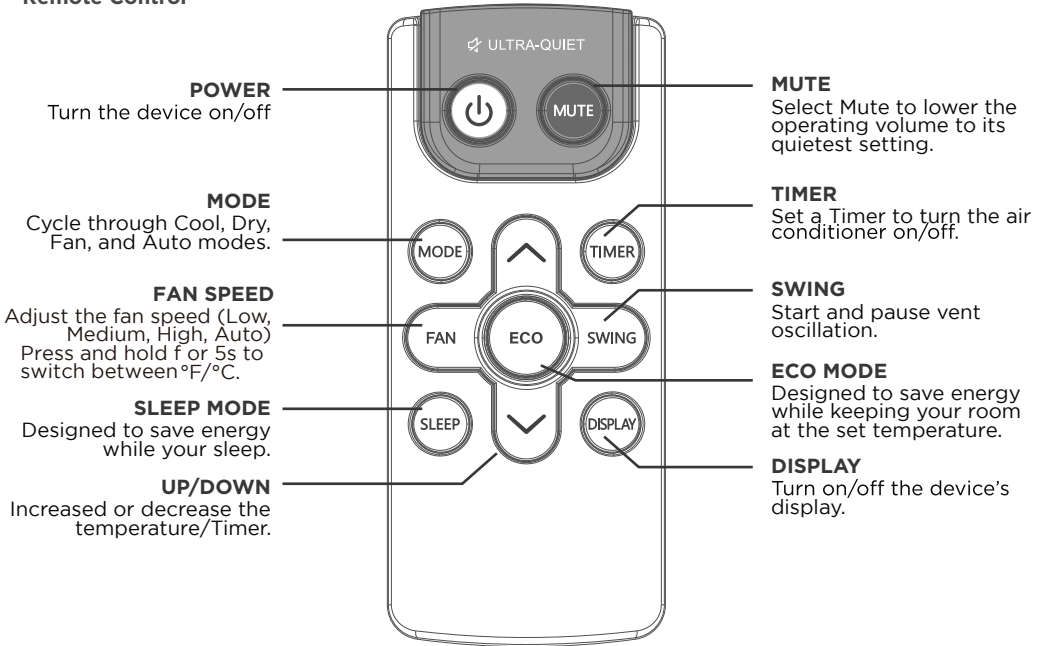

For more information on how to use the remote and other functions of your air conditioning unit, or to understand how each mode works, please refer to the next few pages.

Battery Replacement

The air conditioner comes with two batteries for the included remote control. Please be sure to insert them correctly for proper use of the remote.

Note:

- Do not mix old and new batteries, or batteries of different types
- Do not leave batteries in the remote if you do not plan on using the device for more than 2 months
- Follow your local city ordinances for information on proper disposal of old and used batteries. Do not dispose of batteries in unsorted municipal waste.

Tips for Using the Remote

1. The remote must be used within 26ft of the unit
2. The unit will make a sound when it receives the remote's signal
3. Curtains, other materials, and even direct sunlight can interfere with the infrared signal receiver.
4. Press "MODE" and " ^ " and hold for 3s to reset the wifi setting.

CLEANING AND MAINTENANCE

Care and Cleaning

Clean your air conditioner occasionally to keep it looking new. Be sure to unplug the unit before cleaning to prevent shock or fire hazards.

Air Filter Cleaning

The air filter should be checked at least once every month to see if it needs cleaning. Never use hot water over 104°F (40°C) to clean the air filter. Never attempt to operate the unit without the air filter.

Trapped particles and dust can build up in the filter and may decrease airflow as well as cause the cooling coils to accumulate frost. To clean the air filter:

1. Pull the grille out from the indents on both sides at the front and remove the filter inside.
2. Wash the filter using liquid dish soap and warm water. Rinse the filter thoroughly. Gently shake the filter to remove excess water.
3. Let the filter dry completely before placing it into the air conditioner.
4. If you do not wish to wash the filter, you may vacuum the filter to remove the dust and other particles.

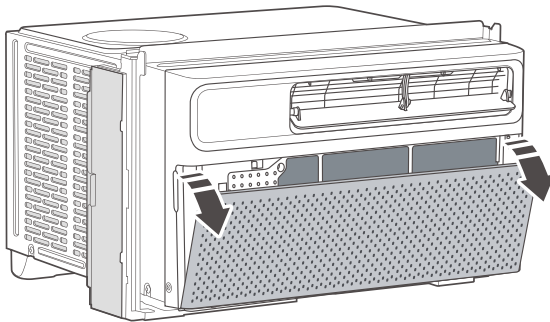

Cabinet Cleaning

To clean the air conditioner cabinet:

- Unplug the air conditioner to prevent shock or a fire hazard. The cabinet and front panel of the air conditioner may be dusted with an oil free cloth or washed with a cloth dampened in a solution of warm water and mild liquid soap. Rinse thoroughly with a damp cloth and wipe dry.
- Never use harsh cleaners, wax or polish on the cabinet front.
- Be sure to wring excess water from the cloth before wiping around the controls. Excess water in or around the controls may cause damage to the air conditioner.

Winter Storage

To store the air conditioner when it is not in use for an extended period of time, remove it carefully from the window according to the installation instructions and cover it with plastic or place it in the original box.

TROUBLESHOOTING

| Problem | Possible Cause | Solution |
|--|---|--|
| The air conditioner will not start | The air conditioner is unplugged | Make sure the air conditioner plug is pushed completely into the outlet. |
| | The fuse is blown/circuit breaker is tripped | Check the house fuse/circuit breaker box and replace the fuse or reset the breaker. |
| | Power failure | <ul style="list-style-type: none"> - The unit will automatically restart when power is restored. - There is a protective time delay (approx. 3 minutes) to prevent tripping of the compressor overload. For this reason, the unit may not start normal cooling for 3 minutes after it is turned back on. |
| | The current interrupter device is tripped | <ul style="list-style-type: none"> - Press the RESET button located on the power cord plug. - If the RESET button will not stay engaged, discontinue use of the air conditioner and contact a qualified service technician. |
| The air conditioner does not cool as it should | Air flow is restricted | Make sure there are no curtains, blinds or furniture blocking the front of the air conditioner. |
| | The temperature control may not be set correctly. | Lower the set thermostat temperature. |
| | The air filter is dirty | Clean the filter. Refer to CLEANING & MAINTENANCE. |
| | The room may be too warm | Please allow time for the room to cool down after turning on the air conditioner. |
| | Cold air is escaping | Check for open furnace registers and cold air returns. |
| | The cooling coils are frozen | Switch to high fan speed and set the thermostat to a higher temperature. |
| | Temperature sensor is not well situated. | Temperature sensor behind the air filter is touching the coil. Try to move it so it does not contact the cold coil. |
| The air conditioner is freezing up | Ice blocks the air flow and stops the air conditioner from cooling the room | Switch to high fan speed and set the thermostat to a higher temperature. |

TROUBLESHOOTING

| Problem | Possible Cause | Solution |
|--|---|--|
| The remote control is not working | The batteries are inserted incorrectly | Check the position of the batteries. |
| | The batteries may be dead | Replace the batteries. |
| Water is dripping outside | Hot and humid weather | This is normal. |
| Water is dripping OUTSIDE when the unit is cooling | The air conditioner is not correctly tilted outside | Improper installation. Tilt air conditioner slightly to the outside to allow water drainage. Refer to installation instructions. |
| Water is dripping INSIDE when the unit is cooling | Moisture removed from the air is draining into the base pan | This is normal for a short period in areas with low humidity and normal for a longer period in areas with high humidity. |
| Noise when the unit starts | A "da-da" sound may occur for 30 seconds when the unit is turned on due to the compressor starting. | This is normal. |

CUSTOMER SUPPORT

Visit our website to contact us, find answers to Frequently Asked Questions, and for other resources which may include an updated version of this user's manual.

 **www.impecca.com**

If you wish to contact us by phone, please be sure to have your model number and serial number ready and call us between 9:00am and 6:00pm ET, at +1 866-954-4440.

Keep tabs on Impecca's newest innovations and enter contests via our social network feeds:

 www.facebook.com/Impecca/

 www.instagram.com/impecca/

 [@impeccausa](https://twitter.com/impeccausa)

ONE-YEAR LIMITED APPLIANCE WARRANTY (US)

Impecca™ warrants this product against defects in material and workmanship to the original purchaser as specified below.

PARTS AND LABOR— if the product is determined to have a manufacturing defect, within a period of one year from the date of the original purchase, Impecca™, at its own discretion, will repair or replace the product parts at no charge to you in the U.S.A.

To obtain warranty service by an authorized Impecca™ service center, please email us at: service@impecca.com to obtain a Repair and Maintenance Authorization (RMA) number and received instructions on how the repair and/or replacement procedure will take place.

Any glass materials included with the appliance will be covered for a period of 60 days from purchase.

Impecca™ specifically excludes from this warranty any non-electric/mechanical attachments, accessories and disposable parts including but not limited to outside case, connecting cables, batteries and AC adapters. Impecca™ reserves the right to repair or replace defective products with the same, equivalent or newer models.

We reserve the right to either repair or replace product at our discretion. Replacement may be either new or refurbished and while every endeavor will be made to ensure it is the same model, if not possible it will be equal or higher specification.

Normal "Wear and Tear" is not covered by this warranty. Further, Impecca™ hereby reserves the right to determine "Wear and Tear" on any and all products. Tampering or opening the product casing or shell will void this warranty in its entirety.

Exclusions: This warranty does not cover the following:

1. Any product that has a defaced or covered serial number.
2. Products that have been transferred to a second owner.
3. Rust on the interior or exterior of the unit.
4. Products listed as "As-Is" or "Refurbished."
5. Food loss due to any product failure.
6. Window air conditioners installed in a wall.
7. The product if used in a commercial setting.
8. Service calls that do not involve product malfunction.
9. Service calls for a product ruined by not following the provided instructions.
10. Service calls to correct improper installation.
11. Costs associated with making the product accessible for servicing (including but not limited to removal of

trim/molding/cabinetry, etc.)

12. Service calls to replace any consumables such as light bulbs, filters, etc.
13. Surcharges that may apply to service calls on weekends, nights, holidays. Damages to the finish of appliance or household furnishings due to installation of appliance.
14. Damages caused by any of the following: Acts of God; fires; misuse; accidents; incorrect power supply; service performed by unauthorized persons; use of non-genuine Impecca parts, etc.

ALL IMPLIED WARRANTIES, INCLUDING IMPLIED WARRANTIES OF MERCHANTABILITY AND FITNESS FOR A PARTICULAR PURPOSE ARE LIMITED IN DURATION TO 1 YEAR FROM THE DATE OF THE ORIGINAL RETAIL PURCHASE OF THIS PRODUCT.

THESE WARRANTIES AND REMEDIES ARE THE SOLE AND EXCLUSIVE WARRANTIES AND REMEDIES IN CONNECTION WITH THE SALE AND USE OF THE PRODUCT. NO OTHER WARRANTIES, ORAL OR WRITTEN, EXPRESSED OR IMPLIED, ARE GIVEN.

IMPECCA™ IS NOT RESPONSIBLE OR LIABLE FOR ANY DAMAGE, WHETHER SPECIAL, INCIDENTAL, CONSEQUENTIAL, DIRECT OR OTHERWISE, OR WHETHER KNOWN OR SHOULD HAVE BEEN KNOWN TO IMPECCA™, INCLUDING LOST PROFITS, GOODWILL, AND PROPERTY AND PERSONAL INJURY RESULTING FROM ANY BREACH OF WARRANTY, THE INABILITY TO USE THE PRODUCT OR UNDER ANY LEGAL THEORY IN CONTRACT OR TORT. IMPECCA LIABILITY IS LIMITED TO THE ACTUAL PURCHASE PRICE PAID TO THE RETAIL SELLER OF THE DEFECTIVE PRODUCT.

No Impecca™ dealer, agent or employee is authorized to make any modification, extension, change or amendment to this warranty without the written consent and authorization from Impecca™.

Some states do not allow the exclusion or limitation of implied warranties or liability for incidental or consequential damages, or do not allow a limitation on how long an implied warranty lasts, so the above limitations or exclusions may not apply to you. This warranty gives you specific legal rights, and you have other rights, which vary from state to state.

Note: Our Warranty center services only to Continental U.S.A.

